

NEW



Lowara ecocirc[®] PRO

THE NEW HIGH EFFICIENCY DOMESTIC HOT WATER PUMPS WITH AUTOMATIC AIR VENTING FUNCTION AND THERMAL INSULATION SHELL

 **LOWARA**
a xylem brand

ecocirc[®] PRO domestic hot water circulation pumps.

Areas of use.

The new ecocirc[®] PRO pumps are now fitted with an automatic air venting function for safe and fast air venting of the pump interior. Operating mode, automatic air venting and faults are shown via a green light in the rotary switch. From the Start position the ecocirc[®] PRO be switched to Stand-by. The ecocirc[®] PRO has a thermal insulation shell fitted as standard.

Variants of these circulation pumps are suitable for use in houses and multiple occupancy dwellings. They comply with [German] Drinking Water Regulations, and by circulating the drinking water they provide effective protection against legionella. Warm water circulation ensures that warm water is immediately available even when the furthest positioned tap is turned on.

Lowara ecocirc[®] PRO circulation pumps are easy to install. To prevent the circulation flow reversing it is recommended that a non-return valve is fitted. In combination with a ball stop valve this also makes it possible to quickly carry out any necessary maintenance or replacement. For ease of installation, models with integrated non-

return and stop valves are available. ecocirc[®] PRO domestic hot water circulation pumps offer minimal power consumption of only 3 watts and they are the only drinking water circulation pumps which enable a stepless speed control. The models with an electronic control thermostat have a fixed rating. The rotary switch is used to set the temperature at which the pump turns off automatically. This means that the pump operating time and the energy required to supply warm water to the storage tank can be reduced to a minimum.

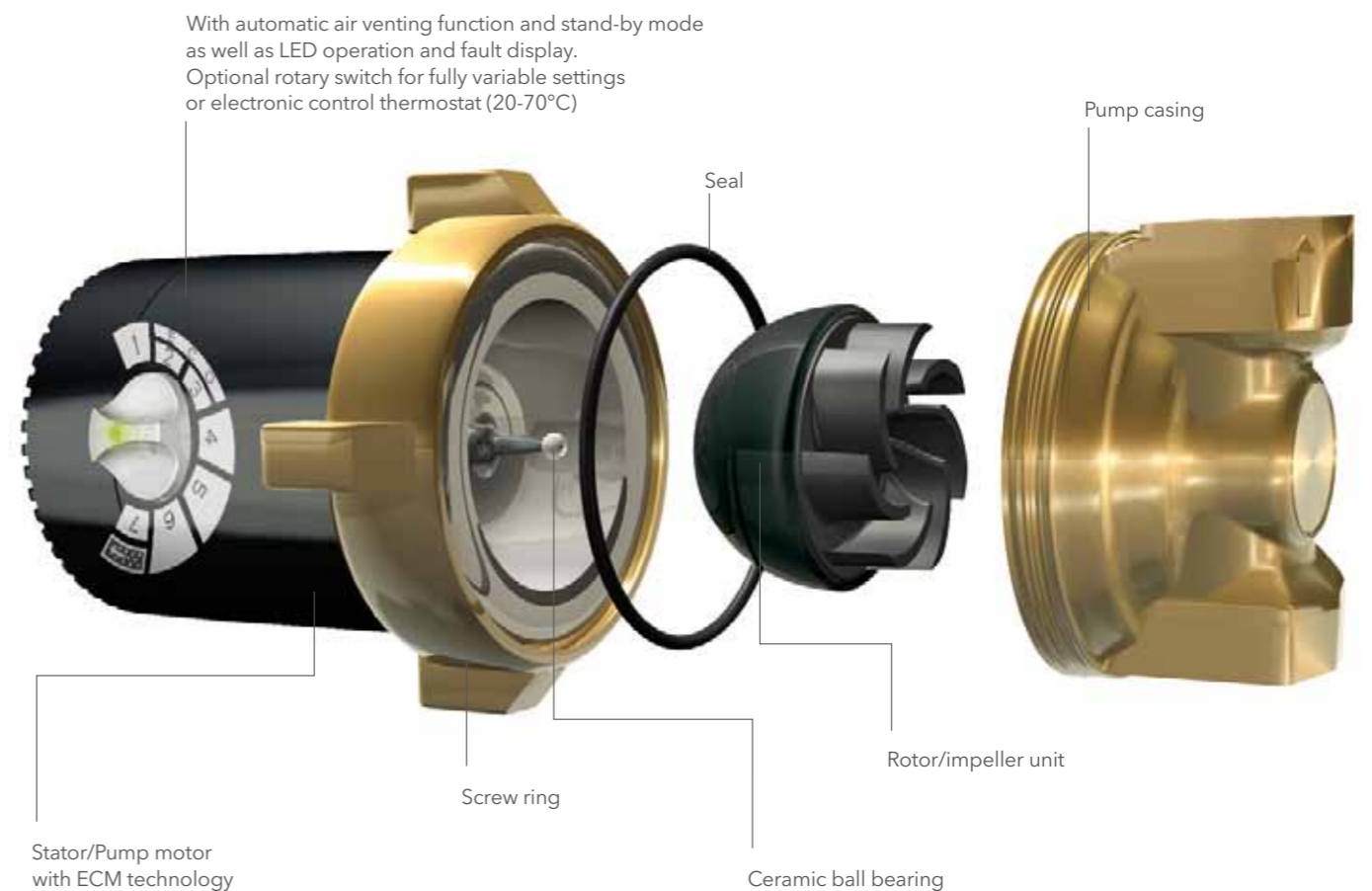

High efficiency Spherical motor.

The only moving part in a spherical motor pump is the rotor/impeller unit, which sits on an ultrahard ceramic ball bearing. There is no conventional shaft with bearings and seals. The spherical mounting of the permanent magnetic rotor/impeller unit on the ceramic ball bearing offers a range of advantages:

The bearing is self-adjusting. This principle means there is no play - and thus no increased noise level - in the bearing and the pump operates quietly all the time. The bearing is directly lubricated and cooled by the pump media (wet rotor circulator). Servicing is therefore not necessary. Since the rotor is held magnetically it avoids even small particles of dirt and will not become blocked under normal operation. Even after a long idle period it will start up again reliably. Limescale can be removed with ordinary household cleaning products.

The model with an electronic control thermostat (model number with "R") allows fully variable adjustment of the desired water temperature. At temperature the pump will switch off. This further reduces the energy consumption costs of the pump, the radiation losses in the circulation pipework and the energy requirements for the supply of warm water.

Energy efficiency with highly efficient ecm technology.

The ecocirc[®] PRO domestic hot water recirculation pumps are highly efficient. ECM technology makes it possible to achieve considerable energy savings without loss in performance. Compared with standard pumps, the start-up torque is also much higher, thus reducing the risk of blockage and calcification.

Up to 90% energy costs saving.

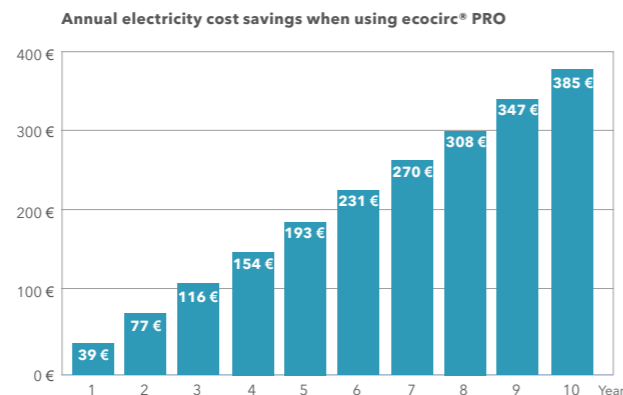
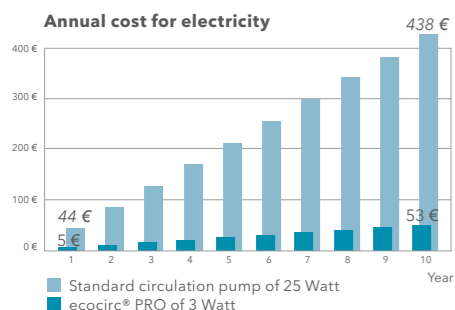

Current cost accounting: to be basically an electricity price of 0,20 €/kWh, pump running time 24 hours/day, 365 days/year.

Costs for electricity are reduced by 90% compared to a standard pump.

High efficiency circulator ecocirc® PRO saves energy, reduces environmental pollution resulting from CO₂ emissions and allows the customer to save money. The cost comparison of a standard circulator of 25 Watt and an high efficiency circulator ecocirc® PRO 15-1 of only 3 Watt power consumption clearly shows the difference.

Thermal insulation shell as standard.

According to German Energy Saving Ordinance requirements ecocirc® PRO is equipped with a thermal insulation shell as a standard without extra charge. Insulation shell avoids unnecessary radiation losses and allows to save energy in the whole system.



ecocirc® PRO domestic hot water recirculation pumps with thermal insulation shell.

Model	Part number	Version	Pump Housing lenght (mm)	Connection	For union fittings	Non-return valve	Timer	Electronic control thermostat (20-70°C)
605005020	ecocirc PRO 15-1/65	1 meter	65	RP 1/2"	AV 1/2" x 1/2"	integrated		
605005100	ecocirc PRO 15-1/65 R							•
605005140	ecocirc PRO 15-1/65 U						•	•
605005180	ecocirc PRO 15-1/65 RU							
605005060	ecocirc PRO 15-1/110		110	G 1 1/4" and RP 1/2"	AV 5/4 x 3/4" and AV 1/2" x 1/2"	integrated with shut-off valve		
605005120	ecocirc PRO 15-1/110 R							•
605005160	ecocirc PRO 15-1/110 U	•					•	
605005200	ecocirc PRO 15-1/110 RU							
605005040	ecocirc PRO 15-3/65	3 meter	65	RP 1/2"	AV 1/2" x 1/2"	integrated		
605005080	ecocirc PRO 15-3/110						110	G 1 1/4" and RP 1/2"

Technical Data

Motor Type	Shaftless spherical motor with highly efficient ECM permanent magnet technology
Max. power consumption	PRO 15-1: 3-9 Watts PRO 15-1 R: 6 Watts PRO 15-1 RU: 8 Watts PRO 15-3: 4-27 Watts
Max. system pressure	10 bar
Electrical connection	230 V, 50 Hz
System temperature	+2 °C to +65 °C
Setting range for electronic control thermostat (optional)	20-70 °C
Protection type/Insulation class	IP 44/F
Pump media	Domestic hot water

Type Designation

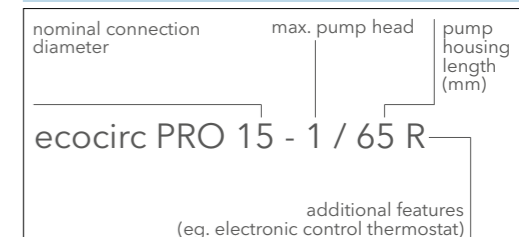

Dimensions

all measurements in mm

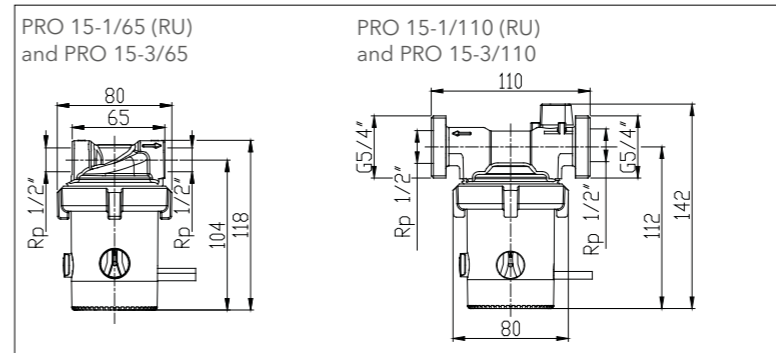

Pump Curves.

PRO 15-1/65
PRO 15-1/65 U

PRO 15-1/110
PRO 15-1/110 U

Power
Version with timer:
+1,5 Watt

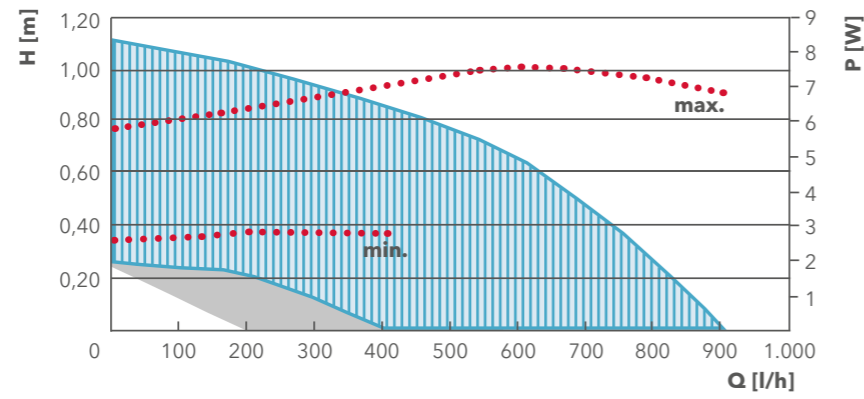

PRO 15-1/65 R
PRO 15-1/65 RU

PRO 15-1/110 R
PRO 15-1/110 RU

Power
Version with timer:
+1,5 Watt

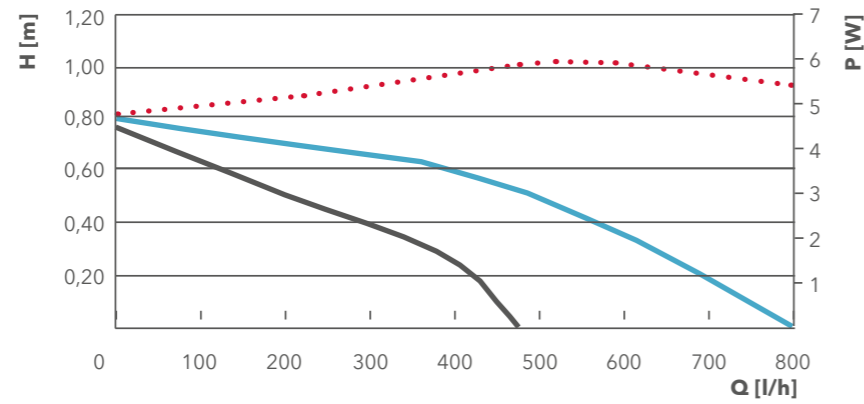

PRO 15-3/65

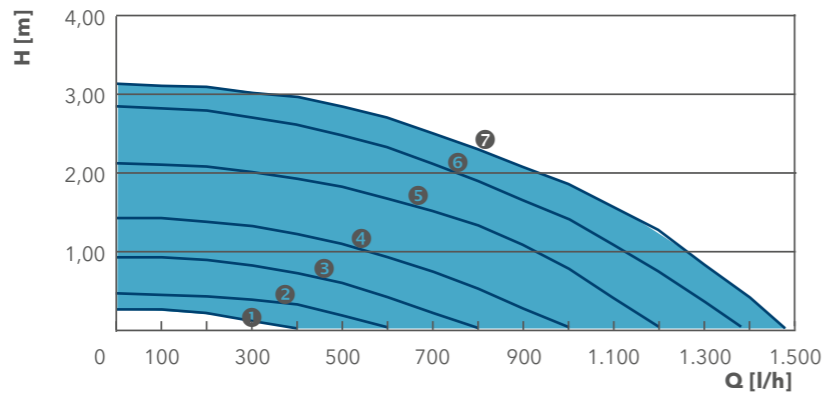

PRO 15-3/110

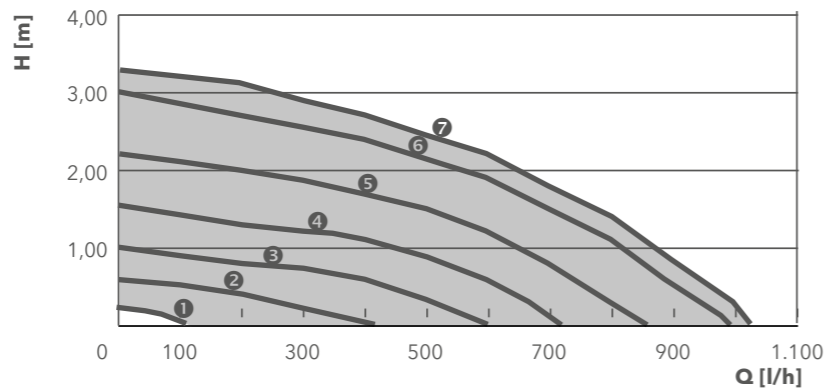

Xylem selection tools.

Xylem offer great online and off-line tools to make a specifier's life easier and for better performance. They are easy to use and minimize the risk of making mistakes in the selection process.

The selection software comes in stand-alone (Loop4U) or web based (xylect.com) versions and allows you to find the best solutions for your pumping problems even without knowing the Xylem product portfolio.

The software let's you search on duty point, application or browse by product.

Detailed output from our tools includes downloadable documents such as data sheets and dimensional drawings in dxf, stp or revit formats.

Besides a comprehensive range of software, Xylem offers a whole range of systems engineering tools for sizing a pump system as well as training in pump sizing and pump systems optimization. And if you need further help, Xylem also has skilled application engineers ready to assist you in designing optimal pumping systems.

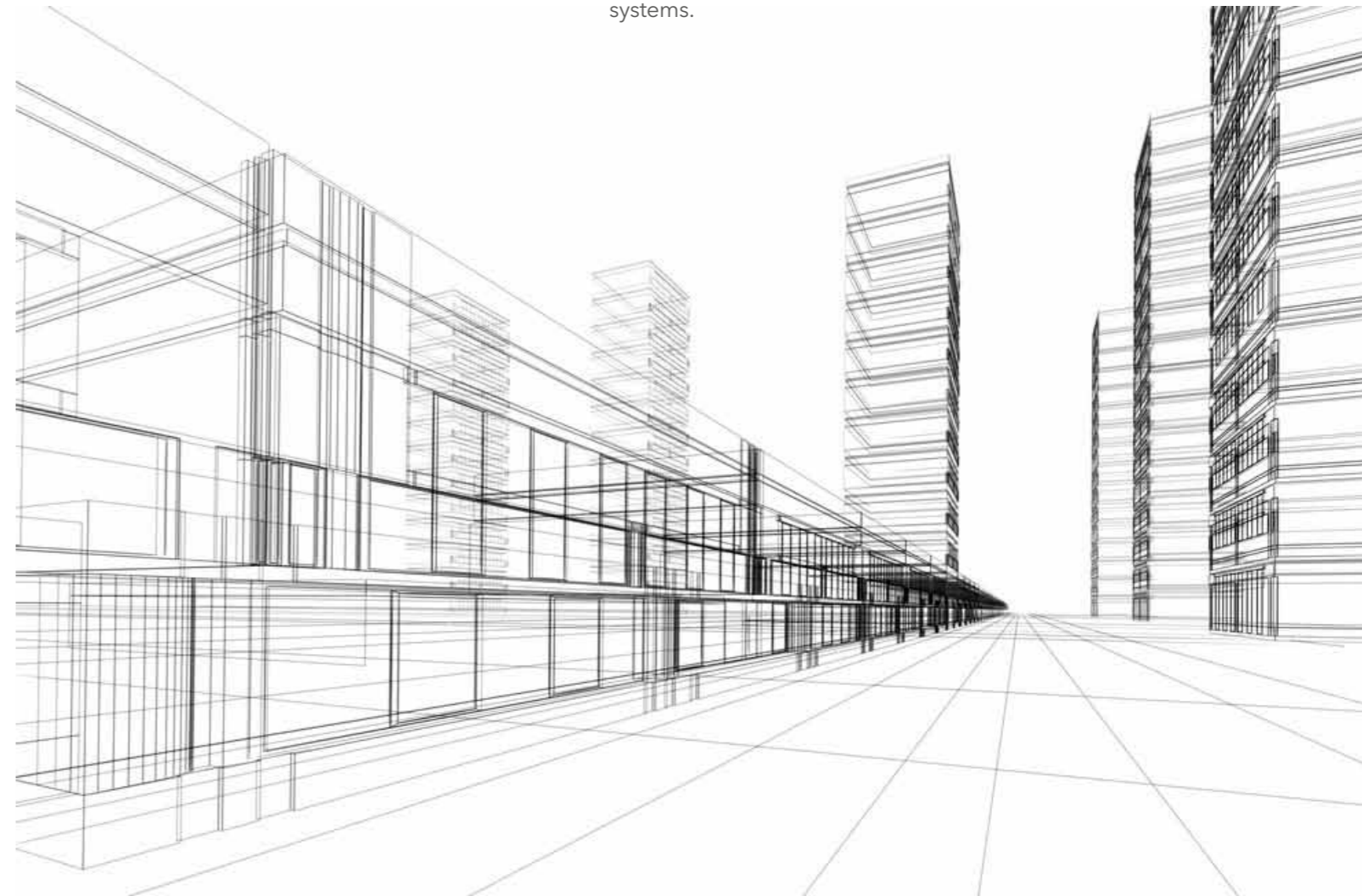

Xylem |'zīləm|

- 1) The tissue in plants that brings water upward from the roots;
- 2) a leading global water technology company.

We're approximately 12,900 people unified in a common purpose: creating innovative solutions to meet our world's water needs. Developing new technologies that will improve the way water is used, conserved, and reused in the future is central to our work. We move, treat, analyze, and return water to the environment, and we help people use water efficiently, in their homes, buildings, factories and farms. In more than 150 countries, we have strong, long-standing relationships with customers who know us for our powerful combination of leading product brands and applications expertise, backed by a legacy of innovation.

